

# Navig8 Electric™

## Unmanned Aerial Vehicle

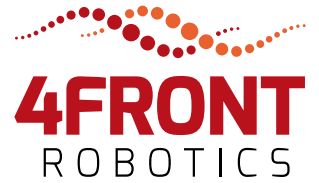

## Highly Maneuverable Portable UAV for Complex Indoor/Outdoor Environments

### SYSTEM DESCRIPTION:

Portable twin-shrouded-prop electric maneuverable VTOL UAV for indoor or outdoor operations inside confined spaces. The variable-pitch props & the dual ducted optimal design enables the UAV to have greater payload capacity (50-60% more) and fly for longer periods of time when compared to similar size UAVs. This UAV has limited knife-edge maneuver capabilities (when compared to our Navig8 UAV). When coupled with our proprietary zero thrust tail rotor this UAV is easier to fly and more stable compared to other electrically powered VTOL UAVs while still being able to perform some knife-edge maneuvers useful for navigating at high speeds in confined spaces. The shrouded props tilt, individually, about two inclined axes/spars for pitch and yaw control, which enables this UAV to execute a wide variety of missions and fly in close proximity to objects without affected by potential flow (e.g. ground/wall) effects.

With 4Front Robotics' navigation flight control system, developed specifically for 3D confined spaces, the Navig8™ electric family of UAVs is the first indoor cost-effective and scalable UAV capable of maneuvering and performing missions in complex spaces. This UAV fulfills the need for a highly portable electric VTOL that can be used for policing (Traffic accident reconstruction, forensics), search & rescue, infrastructure & powerline inspection, and many other tasks where there is a need to perform flights in close proximity to objects.

The Navig8™ electric UAV can be controlled manually (via a RC control joystick) or perform missions autonomously via an on board computer connected to a ground control station from where flight missions can be loaded and changed as the aircraft flies. Using 4Front Robotics 3D navigation algorithms for confined spaces and real-time 3D map generation this UAV makes autonomous navigation and maneuvering decisions on the fly.

#### MAILING ADDRESS:

177 Tuscany Glen Place N.W.  
Calgary, Alberta, T3L 2Z3  
Canada

#### CONTACT INFO:

Dr. Alex Ramirez-Serrano  
Phone: +1.403.400.2991  
Email: [aramirez@4FrontRobotics.com](mailto:aramirez@4FrontRobotics.com)  
Website: [www.4FrontRobotics.com](http://www.4FrontRobotics.com)

## TECHNICAL SPECIFICATIONS:

**Dimensions:** 32.5-64.6 x 29-52 x 9.5-13.6 in (various sizes)  
L x W x H Fully scalable, can be enlarged/reduced

**MTOW:** 12-25 lbs (including batteries)

**Ducted fan diameter:** 9-16 in 229 - 406 mm

**Payload @ MTOW:** 5-10 lbs

**Max speed:** 73-83+ km/hr

**Control Modes:** Manual,  
Thrust vectoring + Semi-Autonomous,  
Active tail rotor Fully Autonomous

**Endurance:** 40-50 minutes  
depends on power supply and UAV size/configuration.

**Sensors:** Dual EO/IR camera, IMU, GPS, LiDAR  
Navigation & Mission Altimeter, 3D camera, magnetometer, etc.

**Electrical power:** Lithium Ion batteries (number & capacity depends on UAV size and configuration). There is the option to recharge the UAV by simply plugging it to a standard 120 VAC outlet (this is not a standard feature).

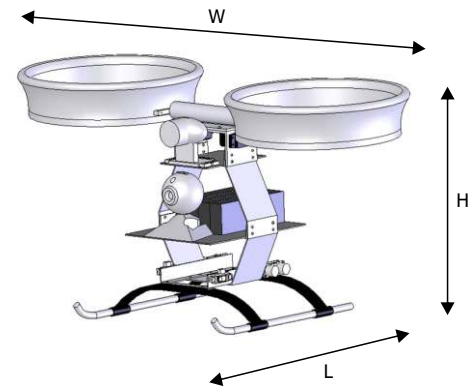

## CAPABILITIES & APPLICATIONS:

The Navig8™ electric UAV can be equipped with multiple payload options (e.g., dual EO/IR cameras, LIDAR, etc.) as well as mission specific sensors (e.g., environment quality monitoring, gas sniffers, 3D cameras, etc.). Two counter-rotating fixed pitched propellers, with direct drive by dedicated electric motors provides the lift/propulsion system. The control system consists of: roll control by differential propeller speed; vertical motion control by collective propeller speeds; pitch yaw and forward motion control via combined longitudinal tilting of the ducted fans by servo actuators and zero lift tail rotor.

## AREAS OF USAGE:

Policing, Traffic incident investigation, Forensics, Search & rescue, Security of critical infrastructure, Pipeline monitoring & leak detection in oil and gas facilities, Fire department activities, forestry, surveillance, etc.  
[Contact us for possible & custom configurations for your specific application.](#)

### CONTACT INFO:

Dr. Alex Ramirez-Serrano  
Phone: +1.403.400.2991  
Email: [aramirez@4FrontRobotics.com](mailto:aramirez@4FrontRobotics.com)  
Website: [www.4FrontRobotics.com](http://www.4FrontRobotics.com)